

Purpose:

The Roller Wheel Sub is a tool used to significantly reduce friction when deploying slickline tool strings into highly deviated wellbores.

Application:

Can be ran in between each connection of the tool string as required.

Disassembly:

Remove Spring Pins from Body.

Remove Dowel Pins from Wheels and Body.

Remove Roller Wheels from Body.

If required, Bushing can be pressed out and replaced with a new Bushing if worn.

Remove QC Lock Plate from Body by compressing the Spring and pushing the Lock Plate out the side of the Body.

Remove Spring from Body.

Clean all parts and inspect for wear.

Assembly:

Install Busing into Wheel by using a press to push it in flush.

Install Wheel into Body and align the holes in the Body and the Wheel.

Install Dowel Pins through the Wheel and into the Body.

Install Spring Pin into Body to hold Dowel Pins in place.

Install Spring into QC Box on Body.

Compress Spring and install Lock Plate into Body.

Precautions:

Check all parts for wear after each use.

ITEM	QTY	DESCRIPTION	PART NUMBER	MATERIAL
1	1	BODY	01-01-RWS-150-03	AISI 4140 - L80
2	6	ROLLER	01-01-RWS-150-02	AISI 4140 - P110
3	1	LOCKING PLATE	01-01-QC-150-01	1018
4	1	SPRING	01-01-QC-150-02	INCONEL X-750 SPRING TEMP
5	6	DOWEL PIN	1/4 x 5/8 DOWEL PIN	18-8 STAINLESS STEEL
6	6	SLOTTED SPRING PIN	3/16 x 7/8 LG SLOTTED PIN	STEEL
7	6	BUSHING	01-01-RWS-150-07	BRASS

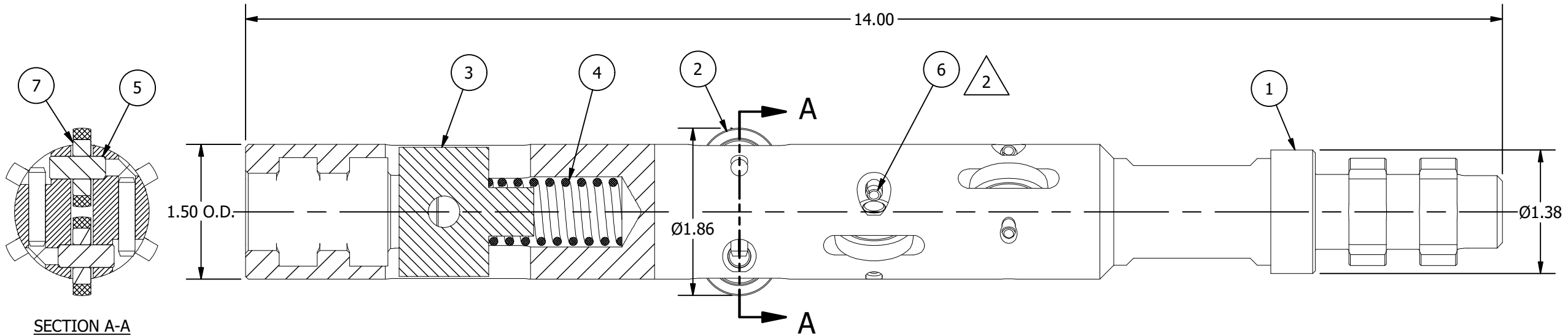
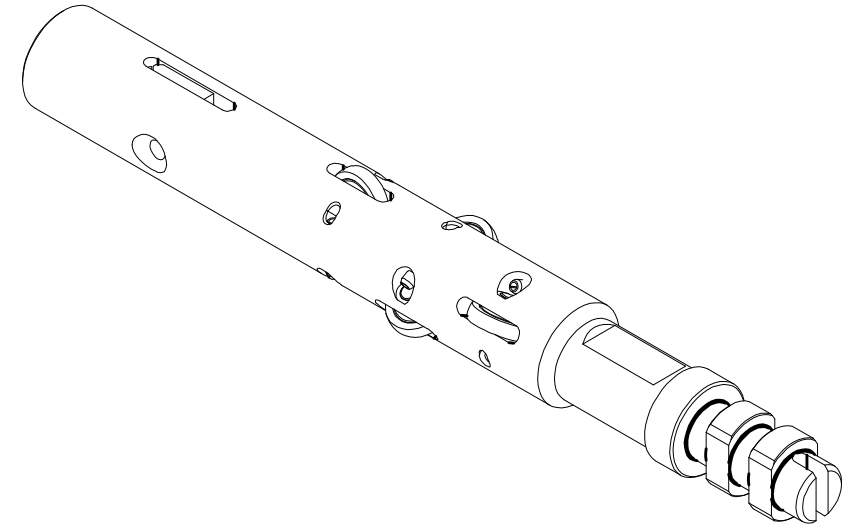

THIS DOCUMENT IS THE SOLE PROPERTY OF BRACE TOOL INC. IT CONTAINS CONFIDENTIAL AND PROPRIETARY INFORMATION; IT IS DISTRIBUTED WITH THE UNDERSTANDING THAT IT WILL NOT BE REPRODUCED OR USED FOR ANY PURPOSE EXCEPT THE CONFINED FUNCTION OF WHICH IT IS DISTRIBUTED. UPON DEMAND, THIS DOCUMENT SHALL BE RETURNED TO BRACE TOOL INC.				
TOLERANCES .X = +/- 0.030 .XX = +/- 0.015 .XXX = +/- 0.005 $\leq \pm 0.5^\circ$ ◎ = .005 TIR SURFACE FINISH $\sqrt{125}$	THIRD ANGLE PROJECTION ALL DIMENSIONS IN INCHES BREAK SHARP EDGES AND CORNERS 1/64 X 45° UNLESS OTHERWISE NOTED	WEIGHT 4.9 lbmass	MATERIAL AS REQ	
		SCALE NTS	SHEET 1 of 1	TITLE 1.50" ROLLER WHEEL SUB 1.50" Q.C. ASSEMBLY
REV 2	DATE 28 MAY 19	DESCRIPTION REPLACED SET SCREW WITH SPRING PIN	BY HSA	ECR 00520
REV 1	DATE 29 NOV 17	DESCRIPTION UPDATED BOM ITEM (4) AND (5)	BY L.M.B.	ECR 00385
REV 1	DATE 6/27/2017	DESCRIPTION L.M.B.	BY L.M.B.	ECR 00385
REV 2	DATE 5/29/2019	DESCRIPTION C.B.	BY C.B.	ECR 00385

2	28 MAY 19	REPLACED SET SCREW WITH SPRING PIN	HSA	00520
1	29 NOV 17	UPDATED BOM ITEM (4) AND (5)	L.M.B.	00385
REV	DATE	DESCRIPTION	BY	ECR