

REMEMBER..."SAFETY FIRST, EVERY TIME"

- Always use eye protection when using power tools.
- Always wear protective footwear when working in a workshop environment.
- Always wear hand protection and remove jewelry when performing workshop duties.
- Always wear protective head gear when performing workshop duties.
- Always wear ear protection when working in a noisy workshop environment.
- Only use certified equipment.
- Do not manually lift heavy loads, always use a fork lift or gantry crane with a designated operator.

Post Job Maintenance:

- Remove the ram assemblies from the wireline valve.
- Remove any well deposits and clean the wireline valve.
- Close each hydraulic cylinder and remove the ram and inspect.
- Manually close hydraulic back up.
- Remove ram guides and inspect for damage.
- Replace any damaged O-rings and back-ups.
- Remove equalizing assembly and clean.
- Check all threads and apply copper-slip.
- Inspect all seals and sealing surfaces.
- Update inspection and maintenance file for the wireline valve and have signed off by the competent person in charge.

On location inspection:

- Open all rams and inspect the inner seals are correct for the cable being ran.
- Inspect the correct orientation for the outer seals, upper ram face up, lower face down when being used for a braided line application.
- Inspect the ram guides are correct for the cable being ran.
- Open and close all rams.
- Open and close the equalizing assembly.
- Check inspection band to ensure the equipment is in current certification and rating for the operation.
- Follow the pre-job pressure testing guidelines on page 6 & 7.

Operation:

- Closing the wireline valve rams is achieved by hydraulically operating the cylinders until inner seals butt together internally at the center of the inner bore.
- With the equalizing valve or by pass plug in the closed position, the outer ram seals will complete the seal in the ram body housing.
- Pressure can now be bled from the lubricator allowing it to be disconnected and hoisted so necessary surface operations can be completed.
- Once the lubricator is reconnected to the top of the wireline valve and lubricator bleed off valves closed, pressure can be equalized back to the lubricator from the lower side of the rams by opening the valve seat or bypass plug of the equalizing assembly.
- The equalizing assembly is located on the side of the main body, with one bleed off port and located 90° from ram housings. Using an Allen wrench to open the valve seat equalizing assembly allows pressure to be returned to the lubricator from the wellbore with rams closed.
- The wireline valve rams can now be opened by hydraulically operating the rams open, resuming wireline operation.

Precautions:

- Ensure that a hydraulic wireline valve always has the bridals on the opposite side of the wire, in case there is a need to fix or replace any items. This way the operator will not be in line with the wire.
- Always have the wireline valve equalizing assembly on the opposite side of the wire, in case there is a need to equalize. This way the operator will not be in line with the wire.
- Never open a closed wireline valve without opening the equalization system.

Tool List:

1. Socket set.
2. Spanner set.
3. Allen key set.
4. Screw driver set
5. Brass punch set.
6. Circlip pliers.
7. O-ring pick.
8. Plastic hammer.
9. 12" adjustable spanner.
10. Vice.
11. Grease.
12. Hydraulic oil.
13. Anti-seize protective compound.
14. PTFE thread tape.
15. Clean rags.
16. Wireline valve control panel, hoses and bridals (if hydraulically operated).
17. Wireline valve schematics for the valve being worked on.
18. Maintenance file for valve being worked on.
19. Complete Brace supplied redress kit suited for the well conditions and equipment specification.

DISASSEMBLY: Reference Bill of Materials for Part Identification

1. Remove adapter plugs from the body.
2. Remove the hexagon socket button head cap screw from the bypass plug.
3. Remove the bleed off plug from the bypass plug.
4. Remove the bypass plug from the body.
5. Remove the adapter plugs and/or hydraulic fittings from the cylinder and drain any excess fluid.
6. Unscrew valve nut, this will back out the hydraulic cylinder from the valve.
7. Have two people for this task so you can guide out the cylinder and prevent the ram from dropping once the ram is visible.
8. Once the ram and the cylinder are free from the body use a bench vise to handle the part removal from the cylinder.
9. Remove the spiraloc ring from the cylinder and slide off the nut.
10. Remove the end cap.
11. Remove the retaining ring (interior) from the end cap.
12. Remove the lock out bolt from the end cap.
13. Remove the piston from the piston shaft (this can be accomplished by using the piston wrench).
14. Remove the piston shaft through front of cylinder.
15. Remove the bushing from piston shaft.
16. Remove the indicator rod from the piston.
17. Remove the internal retaining ring (snap ring pliers required).
18. Remove all V-packing, back up rings, and O-rings from cylinder, piston, and end cap.
19. Clean and inspect all parts for wear or damage.
20. Remove inner and outer seals from rams.
21. Remove the lock out pins and bronze bushings from the hydraulic cylinder.
22. Remove the V-packing, O-rings, and anti rotation pin from the hydraulic cylinder.
23. Remove the lock out bolt from the end cap.
24. Repeat steps 5 thru 23 for the remaining cylinder assemblies.
25. Remove set screws on the top and bottom subs of the wireline valve.
26. Remove the top sub.
27. Remove the bottom sub and union nut.
28. Clean and inspect all parts for wear or damage.
 - a. If any significant damage or wear; replace or repair as per original OEM spec.

ASSEMBLY: Reference Bill of Materials for Part Identification

1. Install two #238 O-rings and #238 back-up rings in the top and bottom of the wireline valve body.
2. Install the top sub into the body of the wireline valve with the wellhead arrow facing down to the bottom sub. ***RECOMMENDED TORQUE –600 FT/LBS***.
3. Install two set screws in the wireline valve body located at the top sub and tighten.
4. Install the bottom sub and hand nut into the body of the wireline valve (the wellhead direction arrow will be pointing towards the bottom sub and hand nut.) ***RECOMMENDED TORQUE -600 FT/LBS***.
5. Install two set screws in the wireline valve body located at the bottom sub and tighten.
6. Install one #111 O-ring onto the two adapter plugs.
7. Install the adapter plugs into the body of the wireline valve.
8. Install the #009 O-rings and #009 back up rings on the bleed off plug and install into the by-pass plug.
9. Install the #114 O-ring and #114 back-up ring onto by-pass plugs.
10. Install the by-pass plug into the body of the wireline valve.
11. Install one hexagon socket button head cap screw into the by-pass plug.
12. Install the #236 O-ring and #236 back up ring into the hydraulic cylinder.
13. Install the #215 O-ring and #215 back up ring into the inside of the cylinder and end cap.
14. Install the “T” seal and back up rings on the piston.
15. Install the #234 O-ring and #234 back up ring onto the end cap.
16. Install the #124 O-ring on the outside of the male back up ring and the #121 O-ring on the inside of the male back up ring.
17. Install the female back up ring into the packing bore of the cylinder with the V-groove exposed.
18. Install the V-packing into the packing bore of the cylinder so that it fits into the female back up ring.
19. Install the male back up ring into the packing bore (take care to ensure that the external #124 O-ring is not scored).
20. Install the internal retaining ring (snap ring pliers required).
21. Install the piston onto the indicator rod and tighten.
22. Install the bronze bushing onto the piston shaft and install into the cylinder through the packing and back up rings. (take care not to score the O-rings when sliding the threads of the piston shaft though).
23. Install the piston into the cylinder and thread onto the piston shaft (this can be accomplished by using the piston wrench).
24. Install the end cap onto the cylinder (care should be taken to ensure that the O-rings and back up rings are not damaged.).
25. Install the lock out bolt into the end cap.
26. Install the stop ring against the lock out bolt.
27. Install the internal snap ring into the end cap.
28. Install the nut onto the cylinder.
29. Install the spiroloc retaining ring onto the cylinder to the first groove closest to the end cap.
30. With piston in the closed position, fill the cylinder with hydraulic fluid via the NPT port in the end cap.
31. Install the desired hydraulic fittings.
32. Install the desired inner and outer seals onto the rams using the key retainer to retain the inner seals.
33. Install the lock out pin and bushing into the “T” slot of the ram. The bushing is to act as a bearing between the “T” slot and the lock out pin.
34. Install the anti rotation pin into the cylinder. (This is accomplished by dropping the pin through the alignment slot on the ram, aligning with the threaded hole in the cylinder and tightening with a wrench.)
35. Install the ram and hydraulic cylinder assembly into the body of the wireline valve by pushing the ram into the body far enough that the nut can engage the threads. (Ensure that the outer seal is facing up and the locating pin is lined up with the locating pin hole on the cylinder.)

ASSEMBLY: Reference Bill of Materials for Part Identification

36. Move the spiraloc retaining ring to the grove closest to the nut, which allows you to remove the cylinder via the nut at the disassembly stage.
37. Repeat steps to 12-36 for additional hydraulic cylinder assembly.
38. It is recommended that a function test is performed after assembly before being put into service.
39. It is recommended that a pressure test be performed at this point to verify wireline valve integrity, as per your local regulations.

Pressure Testing Guidelines for a Slickline Wireline Valve:

- Confirm that all personnel are deemed competent to perform the task.
- Document all changes, configurations and repairs made to the equipment and keep copies in your company maintenance files.
- Sign off completed pre-job inspection checklist.
- Place signs and barriers warning all personnel of the defined test area.
- Ensure clear radio communication between the controller of the pressure test unit (PTU) and the supervisor in charge of the test.
- Ensure all personnel without radio communication are in a clear line of visibility.
- Ensure constant communication between the PTU operator and the supervisor.
- Pressure test as per local regulations or manufacture guidelines.

Pressure Testing Guidelines for Slickline Wireline Valve dressed with Blind Ram Seals:

- Install the wireline valve and connect bridals and hoses to wireline valve panel/hand pump.
- Make an announcement for pressure testing, so everyone in the area is aware of the danger.
- Open the equalizing port.
- Partially close blind rams, leaving enough gap to allow test fluid overflow above the rams to expel any air in the system.
- Fill with test fluid.
- Cease pumping fluid when the fluid is level with the blind rams.
- Close the blind rams.
- Instruct the pressure pump operator to pump slowly and wait for fluid to overflow over the blind ram via equalization port or manifold if the test is being done with the lubricator in position.
- Stop pump operator and close equalization ports.
- Perform initial low-pressure test. The test is a 5-minute, 300 psi test to ensure the integrity of the pressure test lines etc.
- Perform the high pressure test as per company's pressure test procedure, typically working pressure rating.
- Pressure up slowly in stages to the required test pressure. Ensure this figure does not exceed the working pressure.
- On completion of a successful blind ram test, bleed pressure back to zero via PTU.
- Open equalization ports (slowly) on the wireline valve to dispel any residual low pressure.
- Open the wireline valve blind ram.
- Close the equalization ports and continue pressure test procedure.

Pressure Testing Guidelines for Braided Line Wireline Valve:

- Confirm that all personnel are deemed competent to perform the task.
- Document all changes, configurations and repairs made to the equipment and keep copies in the maintenance files.
- Sign off completed pre-job inspection checklist.
- Place signs and barriers warning all personnel of the defined test area.
- Ensure clear radio communication between the controller of the pressure test unit (PTU) and the supervisor in charge of the test.
- Ensure all personnel without radio communication are in a clear line of visibility.
- Ensure constant communication between the PTU operator and the supervisor.
- Ensure all grease lines and sufficient injection grease is available for the operation duration.
- For hydraulic wireline valves connect bridals and hoses to control panel and grease injection ports.
- Make an announcement for pressure testing, so everyone in the area is aware of the danger.
- Install the correctly sized test rod and close lower ram and apply ram pressure, ensuring the rod is tied off correctly with certified strop and shackles.
- Inject grease and close upper and lower rams on the test rod applying equal pressure on both top and bottom rams.
- Apply injection grease pressure between the rams.
- Open the equalizing port to remove air pocket.
- Instruct the pressure pump operator to pump slowly and wait for test fluid to overflow over the wireline valve ram via equalization port.
- Stop the pump operator and close equalization ports.
- Perform initial low-pressure test. This is a 5-minute test, 300 psi test to ensure the integrity of the pressure test lines etc.
- Perform the high-pressure test as per company's pressure test procedure, typically working pressure rating.
- Pressure up slowly in stages to the required test pressure. Ensure this figure does not exceed the working pressure.
- On completion of a successful ram test, bleed pressure back to zero via PTU..
- Open the equalization ports on the wireline valve to dispel any residual low pressure.
- Open the wireline valve rams.
- Close equalization ports and continue pressure test procedure.

Inspection & Testing

- Brace Tool recommends a complete tear down inspection after any procedure that may expose the wireline valve to sand, salt, KCL water, or like fluid, extended periods of H₂S service, or any other corrosive or oxidizing fluids or materials.
- Brace Tool recommends a complete tear down inspection at least quarterly based on operational exposure; this may increase at the user's discretion.
- All Pressure Control Equipment must be maintained at regular intervals and re-certified at least once per year with an accurate record of all essential and non-essential maintenance.
- The yearly maintenance procedure should be implemented after any job that exposes the Pressure Control Equipment to conditions, such as accidental drops, corrosive fluids, long durations in position on H₂S or CO₂ or any major maintenance.
- An annual pressure test should be performed when any service requirements are performed.
- After any integral part is removed or replaced that may compromise the integrity of the wireline valve.
- After servicing of the wireline valve.
- After any inspection or repair.
- After any seals are changed out.
- Prior to any pressure test remove any NPT plugs, clean, oil and thread depth check.

AT ANY POINT THAT WELLBORE PRESSURE OR FLUIDS ARE ALLOWED TO ESCAPE UNEXPECTEDLY TO ATMOSPHERE DUE TO FAILURE OF THE WIRELINE VALVE. IT IS RECOMMENDED THAT THE EQUIPMENT BE IMMEDIATELY REMOVED FROM SERVICE AND QUARANTINED UNTIL A COMPLETE INSPECTION, REPAIR, AND PRESSURE TEST CAN BE DONE.

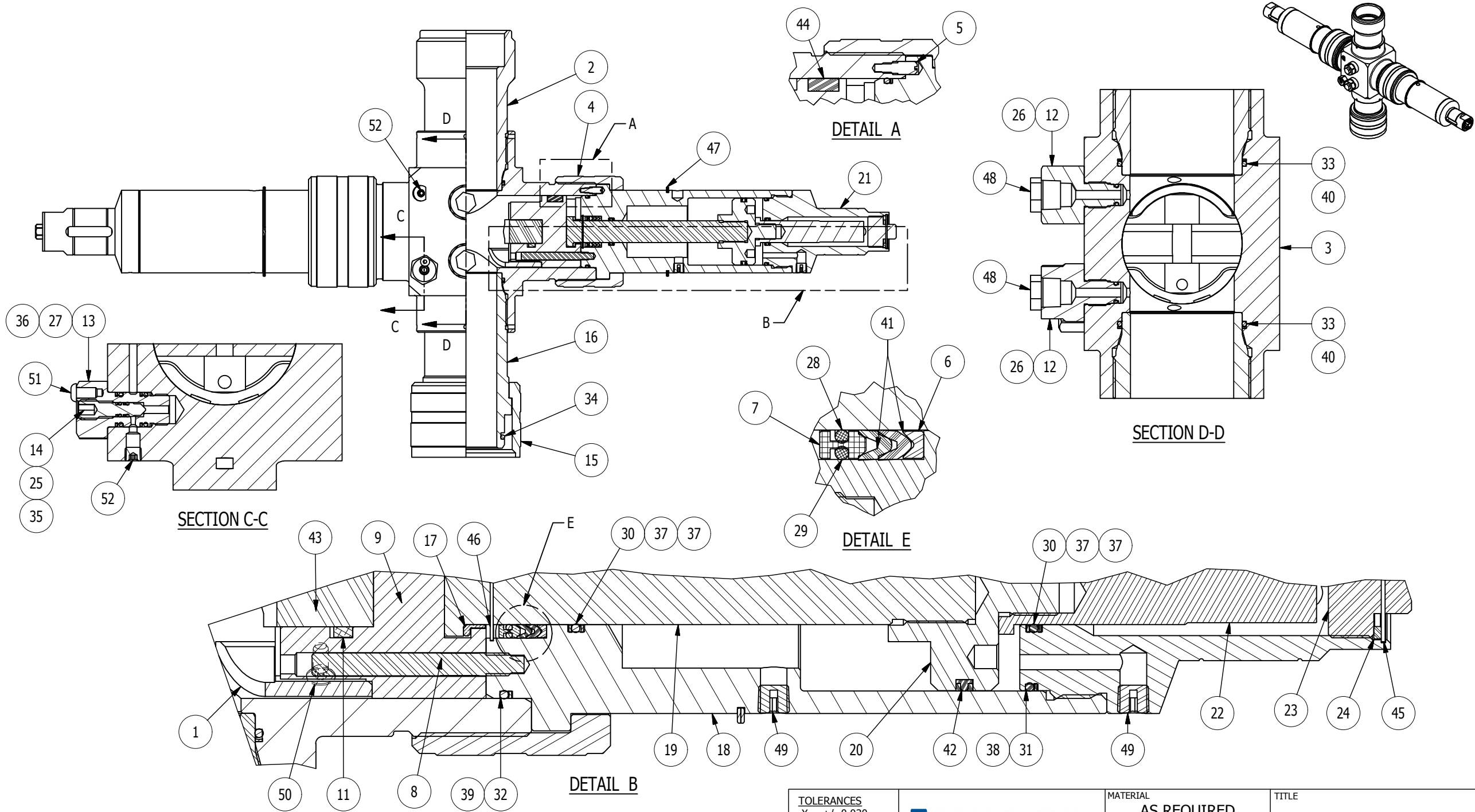

| | | | | |
|-----|-----------|---|--------|-------|
| 2 | 17 APR 15 | UPDATED BOM, WAS 13-01-WLV-300-29, ADDED MISSING BALLOONS | L.M.B. | 00085 |
| 1 | 02 OCT 12 | REASSEMBLED TO ELIMINATE THE SUB ASSEMBLIES | B.L.D. | |
| REV | DATE | DESCRIPTION | BY | ECR |

TOLERANCES
.X = +/- 0.030
.XX = +/- 0.015
.XXX = +/- 0.005
< = +/- 0.5 DEG
© = .005 TIR

BRACE TOOL
TEL (780) 438 - 0441 1-800-438-0061

| | |
|--------------------------------|-------------------|
| MATERIAL AS REQUIRED | |
| SCALE NTS | SHEET 1 of 2 |
| DWN B.L.D. | DATE 6/10/2011 |

| | |
|-----------------------------------|----------|
| TITLE 3" WIRELINE VALVE | |
| 5K HYDRAULIC ACTIVATED | |
| DWG # 13-01-WLV-300-A1 | REV 2 |

| ITEM | QTY | DESCRIPTION | PART NUMBER | COMMENTS | ITEM | QTY | DESCRIPTION | PART NUMBER | COMMENTS |
|------|-----|------------------------|------------------|---------------------------------|------|-----|----------------------------------|----------------------|------------------------|
| 1 | 2 | CABLE GUIDE | 13-01-CG-300-01 | 1026 DOM | 27 | 2 | O-RING | 2-114 | HSN OR AS REQUIRED |
| 2 | 1 | TOP SUB | 13-01-WLV-300-01 | AISI 4140 - L80 | 28 | 2 | O-RING | 2-121 | HSN OR AS REQUIRED |
| 3 | 1 | BODY | 13-01-WLV-300-02 | AISI 4140 - L80 | 29 | 2 | O-RING | 2-125 | HSN OR AS REQUIRED |
| 4 | 2 | NUT | 13-01-WLV-300-03 | 4140 HTSR (28-32 HRC) | 30 | 4 | O-RING | 2-215 | HSN OR AS REQUIRED |
| 5 | 2 | LOCATING PIN | 13-01-WLV-300-04 | AISI 1018 | 31 | 2 | O-RING | 2-234 | VITON 75 |
| 6 | 2 | BACKUP RING | 13-01-WLV-300-12 | BRASS (UNS C36000) | 32 | 2 | O-RING | 2-236 | HSN OR AS REQUIRED |
| 7 | 2 | BACKUP RING | 13-01-WLV-300-13 | BRASS (UNS C36000) | 33 | 2 | O-RING | 2-238 | HSN OR AS REQUIRED |
| 8 | 2 | ANTI-ROTATION PIN | 13-01-WLV-300-15 | 1018 CARBON STEEL | 34 | 1 | O-RING | 2-340 | HSN OR AS REQUIRED |
| 9 | 1 | RAM BLOCK (RIGHT HAND) | 13-01-WLV-300-18 | AISI 4140 - L80 | 35 | 2 | BACKUP RING | 8-009 | NITRILE OR AS REQUIRED |
| 10 | 1 | RAM BLOCK (LEFT HAND) | 13-01-WLV-300-19 | AISI 4140 - L80 | 36 | 2 | BACKUP RING | 8-114 | NITRILE OR AS REQUIRED |
| 11 | 2 | KEY RETAINER | 13-01-WLV-300-23 | 1018 CARBON STEEL | 37 | 8 | BACKUP RING | 8-215 | NITRILE OR AS REQUIRED |
| 12 | 2 | ADAPTER PLUG | 13-01-WLV-300-24 | AISI 4140 - L80 | 38 | 2 | BACKUP RING | 8-234 | NITRILE OR AS REQUIRED |
| 13 | 1 | BY-PASS PLUG | 13-01-WLV-300-27 | AISI 4140 - L80 | 39 | 2 | BACKUP RING | 8-236 | NITRILE OR AS REQUIRED |
| 14 | 1 | BLEED-OFF PLUG | 13-01-WLV-300-28 | 316 STAINLESS STEEL | 40 | 2 | BACKUP RING | 8-238 | NITRILE OR AS REQUIRED |
| 15 | 1 | NUT | 13-06-HUN-300-01 | AISI 4140 HTSR (P110) | 41 | 4 | VALVE PACKING | 1.5 GLV | NITRILE OR AS REQUIRED |
| 16 | 1 | BOTTOM SUB | 13-01-WLV-300-30 | AISI 4140 - L80 | 42 | 2 | T-SEAL | TP034 | AS REQUIRED |
| 17 | 2 | BUSHING | 13-01-WLV-300-31 | BRASS (UNS C36000) | 43 | 2 | INNER RAM SEAL | I-RAM SEAL | NITRILE OR HSN |
| 18 | 2 | CYLINDER | 13-01-WVH-300-01 | AISI 4140 - L80 (NACE MR-0175) | 44 | 2 | OUTER RAM SEAL | O-RAM SEAL | NITRILE OR HSN |
| 19 | 2 | PISTON SHAFT | 13-01-WVH-300-06 | AISI 4140 - L80 (NACE MR-0175) | 45 | 2 | RETAINING RING - INT. | HO-156 | STAINLESS STEEL |
| 20 | 2 | PISTON | 13-01-WVH-300-07 | 17-4 PH (H1150) STAINLESS STEEL | 46 | 2 | INTERNAL RETAINING RING | NA2 - 1 1/2 | SPAENAUER # 254-812 |
| 21 | 2 | END CAP | 13-01-WVH-300-08 | AISI 4140 - L80 (NACE MR-0175) | 47 | 2 | RETAINING RING - EXT. | RST-400 | STAINLESS STEEL |
| 22 | 2 | INDICATOR ROD | 13-01-WVH-300-09 | 17-4 PH (H1150) STAINLESS STEEL | 48 | 2 | HEX HEAD PLUG | 1/2-14 NPT | STEEL |
| 23 | 2 | LOCK-OUT BOLT | 13-01-WVH-300-10 | 17-4 PH (H1150) STAINLESS STEEL | 49 | 4 | SOCKET HEAD PLUG | 1/4-18 NPT | AS REQUIRED |
| 24 | 2 | STOP RING | 13-01-WVH-300-11 | 17-4 PH (H1150) STAINLESS STEEL | 50 | 4 | COUNTERSUNK HEAD CAP SCREW | .250-20 UNC x .63 LG | STEEL |
| 25 | 2 | O-RING | 2-009 | HSN OR AS REQUIRED | 51 | 1 | HEX SOCKET BUTTON HEAD CAP SCREW | .250 - 20 x .50 LG | STEEL |
| 26 | 2 | O-RING | 2-111 | HSN OR AS REQUIRED | 52 | 2 | SOCKET HEAD PLUG | 1/8-27 NPT x .25 LG | STEEL |

APPLICABLE CRITICAL DATA

| DESCRIPTION | DATA |
|--------------------------|------------------------------|
| MINIMUM ID (FULLY OPEN) | Ø3.00 |
| TOP CONNECTION | 4.75-4 ACME PIN |
| BOTTOM CONNECTION | 4.75-4 ACME BOX |
| MAXIMUM WORKING PRESSURE | 5,000 psi |
| TYPE OF SERVICE | H2S |
| SHIPPING DIMENSIONS | 41-11/16" x 20-1/4" x 7-1/4" |
| APPROXIMATE WEIGHT | 180 Lbs |

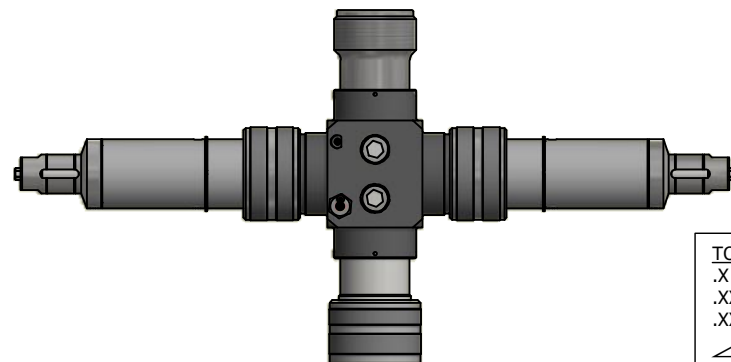

TOLERANCES
.X = +/- 0.030
.XX = +/- 0.015
.XXX = +/- 0.005
< = +/- 0.5 DEG
© = .005 TIR



TEL (780) 438 - 0441 1-800-438-0061

| | | | |
|--------------------------------|--------------------------|-----------------------------------|-----------------|
| MATERIAL AS REQUIRED | | TITLE 3" WIRELINE VALVE | |
| SCALE NTS | SHEET 2 of 2 | 5K HYDRAULIC ACTIVATED | |
| DWN B.L.D. | DATE 6/10/2011 | DWG # 13-01-WLV-300-A1 | REV 2 |